



Fluid Management[®]

HARBIL[®]

NSC80
Compact Colorant
Dispenser

Operating and
Instruction
Manual

Part # - 4700230
Rev. E
06/07/01

CONFIDENTIAL

**PROPERTY OF *FLUID MANAGEMENT*[®]
(C) COPYRIGHT 2001 *FLUID MANAGEMENT*
AS AN UNPUBLISHED WORK ALL RIGHTS RESERVED**

**This material cannot be copied or disclosed to others without
the prior written permission of *Fluid Management*.**

***FLUID MANAGEMENT* A Unit of IDEX, Corp.**

1023 Wheeling Road
Wheeling, Illinois 60090-5776

Voice (847) 537-0880
US (800) 462-2466
Fax (847) 537-5530
www.fluidman.com

Table Of Contents

ASSEMBLY & INSTALLATION-----5
ASSEMBLY & INSTALLATION-----6
BASIC OPERATION -----12
MAINTENANCE PROCEDURES -----13
PARTS:-----14

ASSEMBLY & INSTALLATION

INTRODUCTION

The Harbil NSC80 is a compact manual colorant dispenser that was designed for exceptional reliability and ease of use. It is a nearly maintenance free device that should deliver many years of reliable service. Its features include:

- Heavy-duty components and a durable finish for long wear.
- Bottom agitation linked with rotation of the canisters.
- Special adjustable shelving to accommodate all can sizes.

SPECIFICATIONS

Height 60" (152.4 cm.) *Max*

Width 24" (609.6 cm.)

Depth 30" (762.6 cm.)

Weight 195 lbs" (88.5 kg.)

Motor 1/6 HP (Draws 3.0 Amps @ 115 VAC)

TYPICAL ELECTRICAL SUPPLY

See name plate for specific information.

120 V \pm 10%, 60 Hz 15 Amp

IMPORTANT:



If any damage is found, notify the carrier at once and arrange for inspection in order to claim recovery. Claims for damage must be made by the consignee (YOU). The carrier assumes full responsibility upon acceptance of shipment and will not entertain any claims by the consignor (Fluid Management).

ASSEMBLY & INSTALLATION

MOUNTING THE CANISTERS

The Harbil NSC80 requires only the simple fastening of the individual canisters to the turntable. The canisters must be mounted in the proper order. Do not fill the canisters before that are mounted.

It is critical that the crank be captured by the bushings that are part of the star wheel assembly. For machine configurations containing less than 12 canisters, hole plugs are provided (FM P/N 25956) to cover the unused canister positions.

1. Unplug the machine before installing canisters.
2. The drive star rotates freely around the drive cam mechanism under the turntable. Rotate drive star with fingers (or other object) inserted through the large holes. Rotate until all of the nylon drive star bushings are visible through all of the large holes. (See Figure 1)

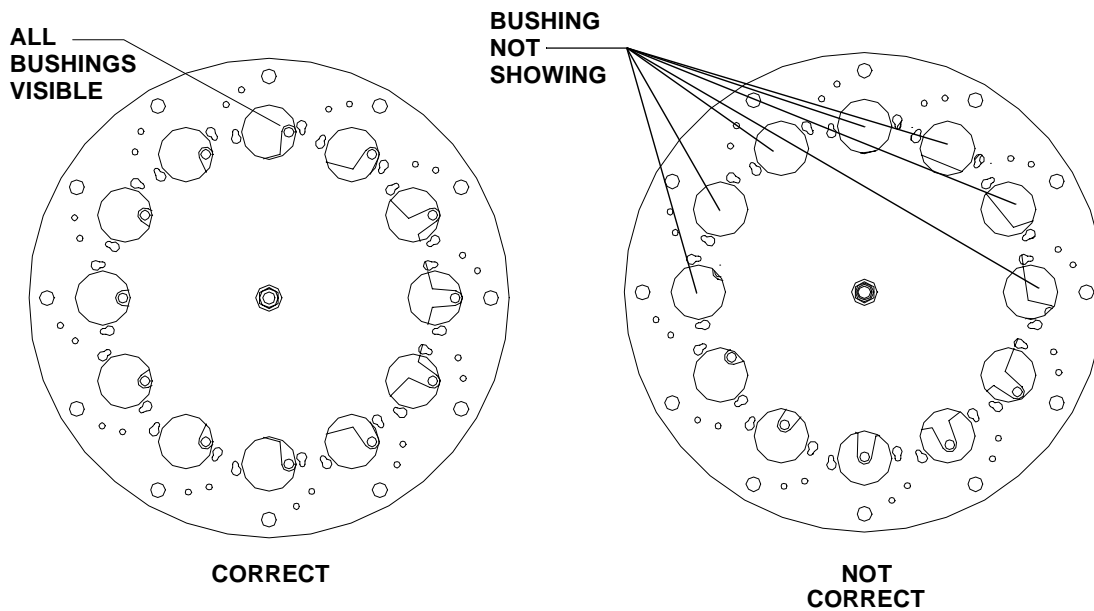

Figure 1 BUSHING ALIGNMENT

3. Insert two screws into the threaded holes on bottom of the canister. Allow about 1/8"-1/4" of thread (3-5 threads) to be exposed, as shown in Figure 2 on page 7.
4. Align the screw heads with the button holes on the turntable for the front canister position and rotate the agitation blade until the agitation crank is aligned with the nylon bushing. (Figure 3 on page 7)

- Lower the canister into position, assuring that the agitation crank is captured by the nylon bushing and that the screw heads pass through the button holes, as shown in figure 3-A. Rotate canister clockwise locking it into place as shown in Figure 3-B.

NOTE: The dispense port will fall through its hole, and the canister will sit flat on the turntable.

- While holding canister in position, secure the canister to the turntable using a screwdriver. Access holes are provided at the bottom of the turntable to tighten the two screws. (Figure 4 on page 8) **Do not overtighten these screws.**

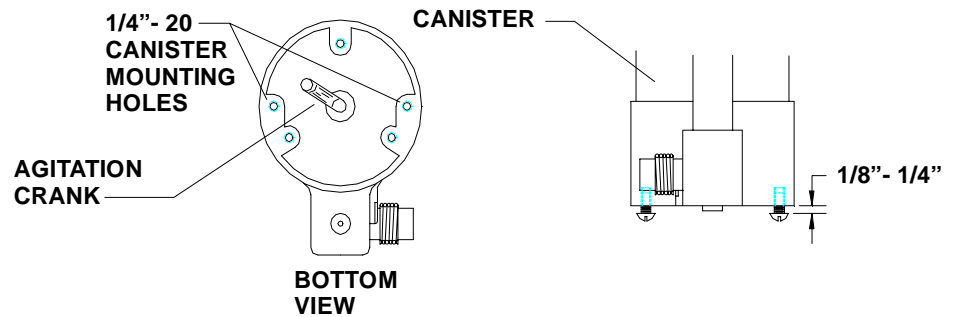

Figure 2 CANISTER

- Verify that the agitation crank is engaged by the nylon drive star bushing. This is done by turning the agitation blade inside the canister. Resistance to turning indicates that the agitation rod is engaged. If the agitation blade turns freely, the agitation rod is not engaged and the canister must be re-mounted.

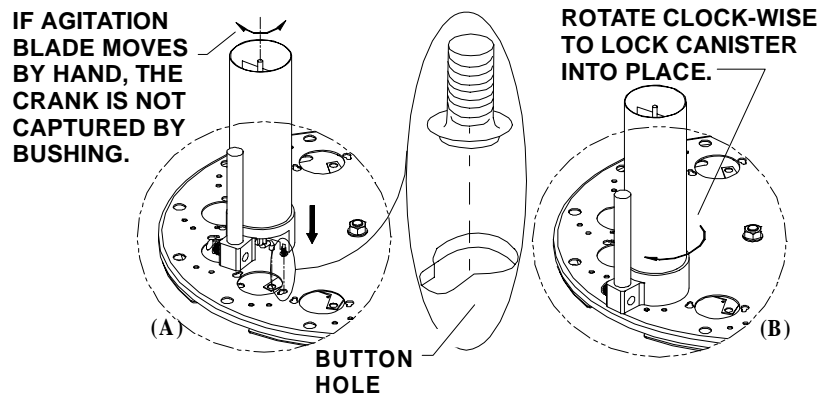

Figure 3 BUTTON HOLE MOUNTING

ASSEMBLY & INSTALLATION

8. After installing the first canister, lower the index lever and rotate the turntable to the next position.
9. Repeat steps 3-6 for each of the remaining canisters until all are installed.
10. After completing canister assembly, connect machine to power, and turn on the agitation switch. Verify that all the agitation blades are turning properly.

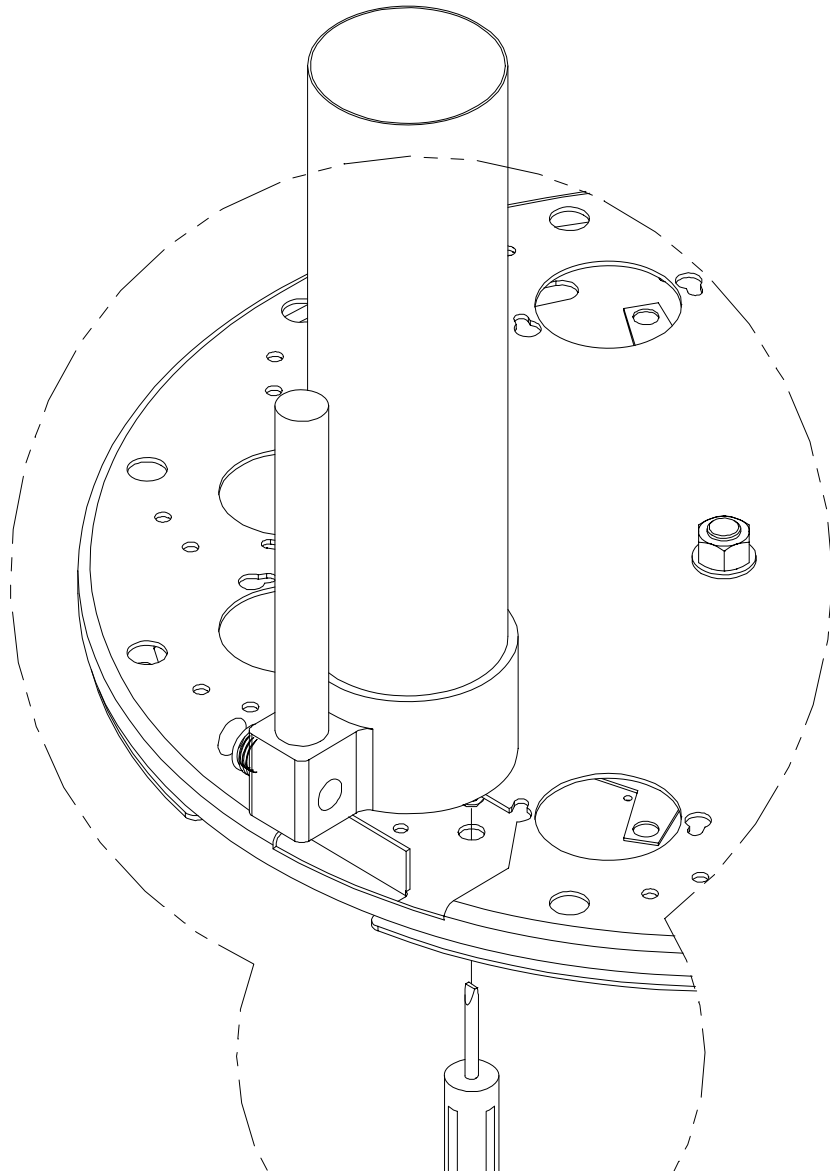

Figure 4 SECURING CANISTER

CONNECTING TO THE POWER SOURCE

GROUNDING

In the event of an electrical short circuit, grounding reduces the risk of electrical shock by providing an escape wire for the electric current. The 3-prong plug, equipped with grounding wire, must be plugged into a 3-slot receptacle that is properly installed and grounded in accordance with all local codes and ordinances.

DANGER:



Improper use of the grounding plug can result in a risk of electric shock.

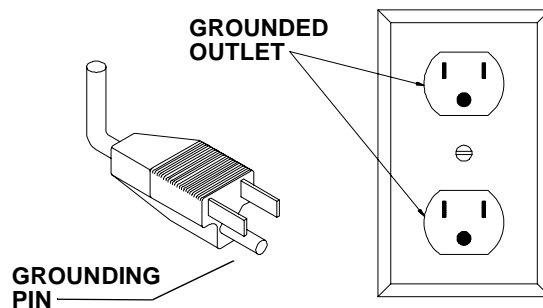

Figure 5 Grounding Methods

DO NOT connect the grounding wire to a flat-blade terminal. The wire with the insulation having an outer surface that is green (with or without yellow stripes) is the grounding wire.

Check with a qualified electrician or serviceman if you are not sure how to ground this machine. **Under no circumstances should you modify the plug if it does not fit the outlet.**

WARNING:



After you have plugged the unit into a dedicated power line and leveled it, inspect to be sure that you have removed the shipping materials.

ASSEMBLY & INSTALLATION

Connect the 115 volt models only to a 115 volt outlet rated at at least 15 ampere. Connect the 220 volt models only to a 220 volt outlet rated at at least 15 ampere. The equipment requires a single, grounded outlet.

EXTENSION CORDS

Extension cords for 220 VAC models are not recommended. If an extension cord is to be used, it should not be combined with others. Use only a 3-wire extension cord that has a 3-pole grounding plug. Power should be provided by a 3-pole receptacle that will accept the plug on the product. Make sure that your extension cord is in good condition. It must have # 16 AWG conductors up to 25 feet long. An extension cord 25 feet long, but no longer than 50 feet is permissible provided it has conductors of at least # 12 AWG. It must be heavy enough to carry the current your product will draw. An undersized cord can cause a drop in line voltage resulting in loss of power, overheating and damage to the motor.

Under no circumstances should you modify the plug if it does not fit the outlet.

Check with a qualified electrician or serviceman if you are not sure how to ground this machine.

DISTANCE	25 ft	50 ft	100 ft	150 ft	200 ft	250 ft	300 ft	400 ft	500 ft
GAUGE SIZE 220V	14	14	12	10	10	8	8	6	6
GAUGE SIZE 115V	14	12	8	6	6	4	4	2	2

FILLING CANISTERS

After all of the canisters have been installed on the turntable, they can be filled. Each canister has a maximum capacity of 2-1/2 quarts. It is recommended that each canister be filled with two (2) quarts of colorant. The maximum capacity of the pump is two (2) ounces.

The following steps represent the process by which the canisters should be filled:

1. Locate the first canister and determine which colorant is to be placed into that canister.
2. Place the appropriate decal on the canister.
3. Shake or stir the colorant following manufacturer's recommendations.
4. Slowly, pour the colorant into the canister to the level of approximately two (2) quarts.
5. Place the top on the canister.
6. Repeat these steps for each of the remaining canisters.
7. After all of the canisters have been filled, agitate by turning on the agitation motor. This will release any air trapped in the colorant.

PRIMING OF PUMPS

Once the canisters have been both filled and agitated, the pumps attached to each of the canisters must be properly primed. Follow these steps to prime the pumps.

1. Locate the first canister.
2. Slowly pull the pump handle all of the way to the top of its stroke and wait in this position for a count of approximately three (3) seconds.
3. Slowly press the pump handle all of the way down to the bottom of its stroke.
4. Repeat these steps five (5) times.
5. Repeat steps 1 through 4 for each of the remaining canisters.

BASIC OPERATION

This dispensing equipment is designed for ease of use. The following steps represent the method by which a formula is to be dispensed:

1. Determine the formula of the color selected by the customer.
2. Refer to the formula book and select the proper base paint.
3. Remove the lid on the base paint.
4. Pull out the appropriate shelf and place the can of base paint on the shelf.
5. Press the indexing lever down and rotate the turntable to the position indicated by the formula book.
6. Turn the pump gauge to center the indicator pointer.
7. Lift the pump handle up until the indicator is opposite the notch on the gauge.
8. Turn the gauge into the notch that represents the desired amount of colorant per the formula book.
9. After the pump handle has been in this position for about three (3) seconds, slowly pull the valve lever down and hold in that position with the left hand.
10. While holding the valve down with the left hand, turn the gauge to the center of the indicator and slowly push the pump handle down all of the way to the bottom of the stroke. This will dispense a metered amount of colorant into the base paint. (Repeat this step as may be required by the formula book.)
11. Referring to the formula book, Pull down the indexing lever and rotate the turntable to the next position indicated and repeat these steps for each of the colorants in the formula.
12. At this point in the process, the can of base paint has been tinted. Remove the can, press the lid back on and mix appropriately.

MAINTENANCE PROCEDURES

To ensure safe, dependable operation of the equipment, follow the maintenance schedule detailed below:

DAILY
Cleaning & Filling:
<ul style="list-style-type: none"> • Agitate colorants every morning for five (5) to ten (10) minutes.
<ul style="list-style-type: none"> • Clean nozzles & outside cabinet surfaces with soap and water.
<ul style="list-style-type: none"> • Check canisters and fill as required.

WEEKLY
Cleaning & Nozzle Maintenance:
<ul style="list-style-type: none"> • Dispense a full measure of any colorant that has not been used during the previous week. Dispense into a clean container and return to the appropriate canister.
<ul style="list-style-type: none"> • Clean all accessible inside surfaces with soap and water.

GENERAL MAINTENANCE

If a nozzle becomes clogged, the obstruction can generally be cleared by inserting a paper clip or similar object in the valve opening. Before inserting such a device, open the valve by pulling the valve lever down and holding while clearing the opening. **BE SURE THAT THE VALVE IS OPENED, AND STAYS OPEN WHILE CLEANING IN THIS WAY. IF THE VALVE CLOSSES AT ANY TIME DURING THIS OPERATION, THE VALVE COULD BE DAMAGED.** If colorant leaks develop at the top of the pump, or if colorant can be observed on the pump piston rod, the pump assembly must be repaired. The Pump Repair Kit (P/N 4223212) can be purchased from the Fluid Management Customer Service Department. A colorant leak at the bottom of the pump assembly generally indicates that the pump assembly has been damaged. In this case, the valve assembly must be replaced with either the Viton Valve Repair Kit (P/N 4231002) or the Thiokol Repair Kit (P/N 4231011).

SPARE PARTS ORDER

Fluid Management Parts Order Form

Photocopy and use this form to
Mail or fax orders to:

Fluid Management A unit of IDEX / **Phone:** 1(800) 462-2466
1023 Wheeling Road | **Fax:** 1(847) 537-5530
Wheeling, IL 60090

Sold To:

Ship To:

Purchase Order Number _____

Ship Via: _____ Collect Prepaid

Taxable Tax Exempt (Fax copy of exemption certificate.)

QUANTITY	PART NUMBER	DESCRIPTION	UNIT PRICE

Comments:

Date:

Signature

PARTS:

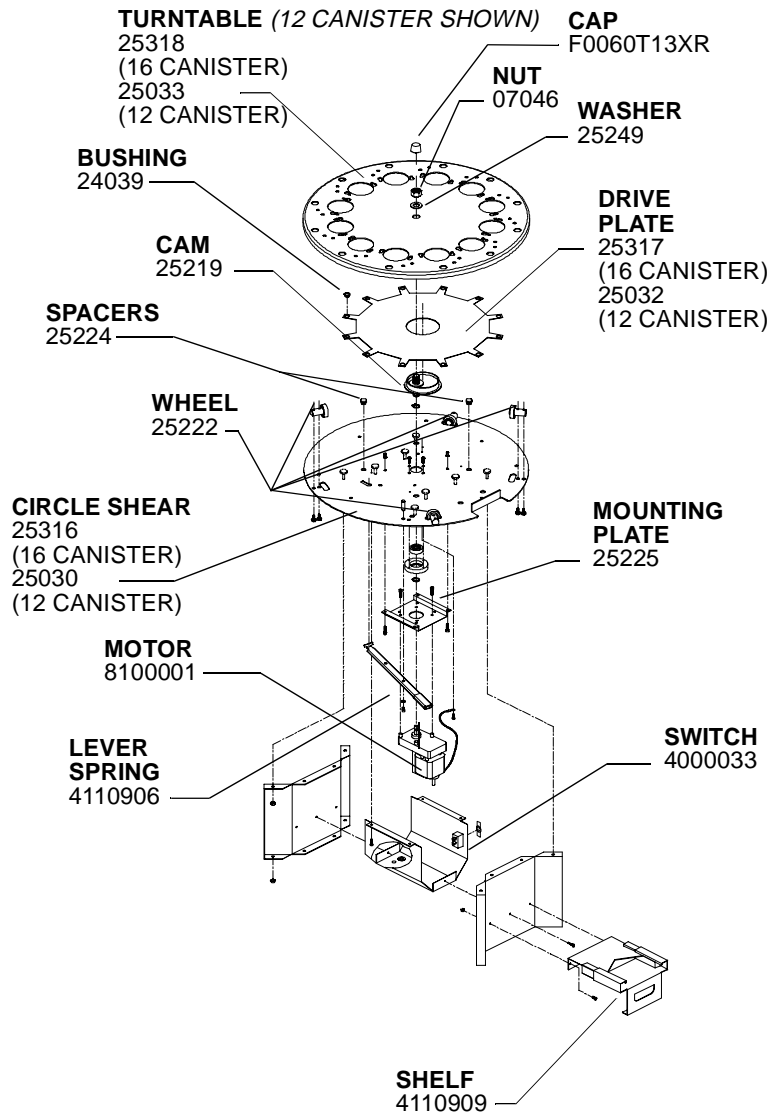

COUNTER TOP MODELS

PART NO	DESCRIPTION	NO REQ
07046	5/8"-11 NUT	1
24039	BUSHING	1 PER CANISTER
25030	CIRCLE SHEAR (12 CANISTER UNITS ONLY)	1
25032	DRIVE PLATE (12 CANISTER UNITS ONLY)	1
25033	TURNTABLE (12 CANISTER UNITS ONLY)	1
25219	CAM ASSY	1
25222	WHEEL	5
25224	SPACER	10
25225	MOTOR MOUNTING PLATE	1
25249	5/8" FLAT WASHER	1
25318	TURNTABLE	1
4000033	POWER SWITCH	1
4110906	LEVER SPRING	1
4110909	SHELF	1
8100001	DRIVE MOTOR	1
F0030T13XR	CAP	1

PARTS:

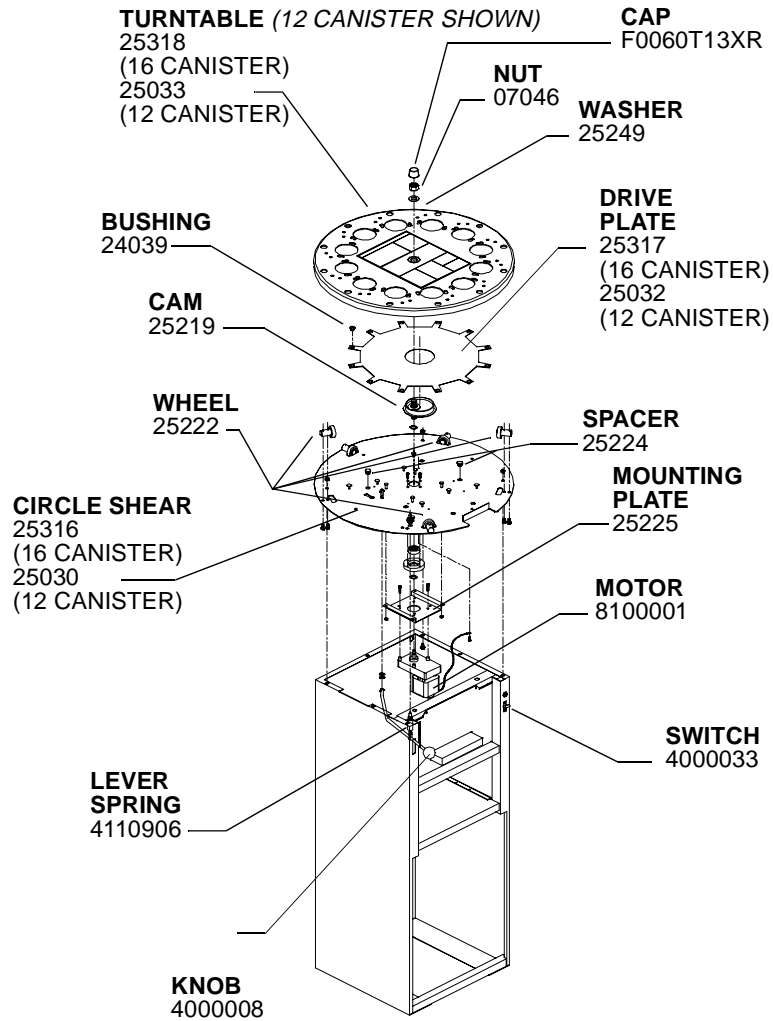

FLOOR MODELS

PART NO	DESCRIPTION	NO REQ
07046	5/8"-11 NUT	1
24039	BUSHING	1 PER CANISTER
25030	CIRCLE SHEAR (12 CANISTER UNITS ONLY)	1
25032	DRIVE PLATE (12 CANISTER UNITS ONLY)	1
25033	TURNTABLE (12 CANISTER UNITS ONLY)	1
25219	CAM	1
25222	WHEEL	5
25224	SPACER	10
25225	MOTOR MOUNTING PLATE	1
25249	5/8" FLAT WASHER	1
25316	TURNTABLE (16 CANISTER UNITS ONLY)	1
25318	TURNTABLE (12 CANISTER UNITS ONLY)	1
4000008	BLACK	1
4000033	POWER SWITCH	1
4110906	LEVER SPRING	1
8100001	DRIVE MOTOR	1
F0060T13XR	CAP	1

PARTS:

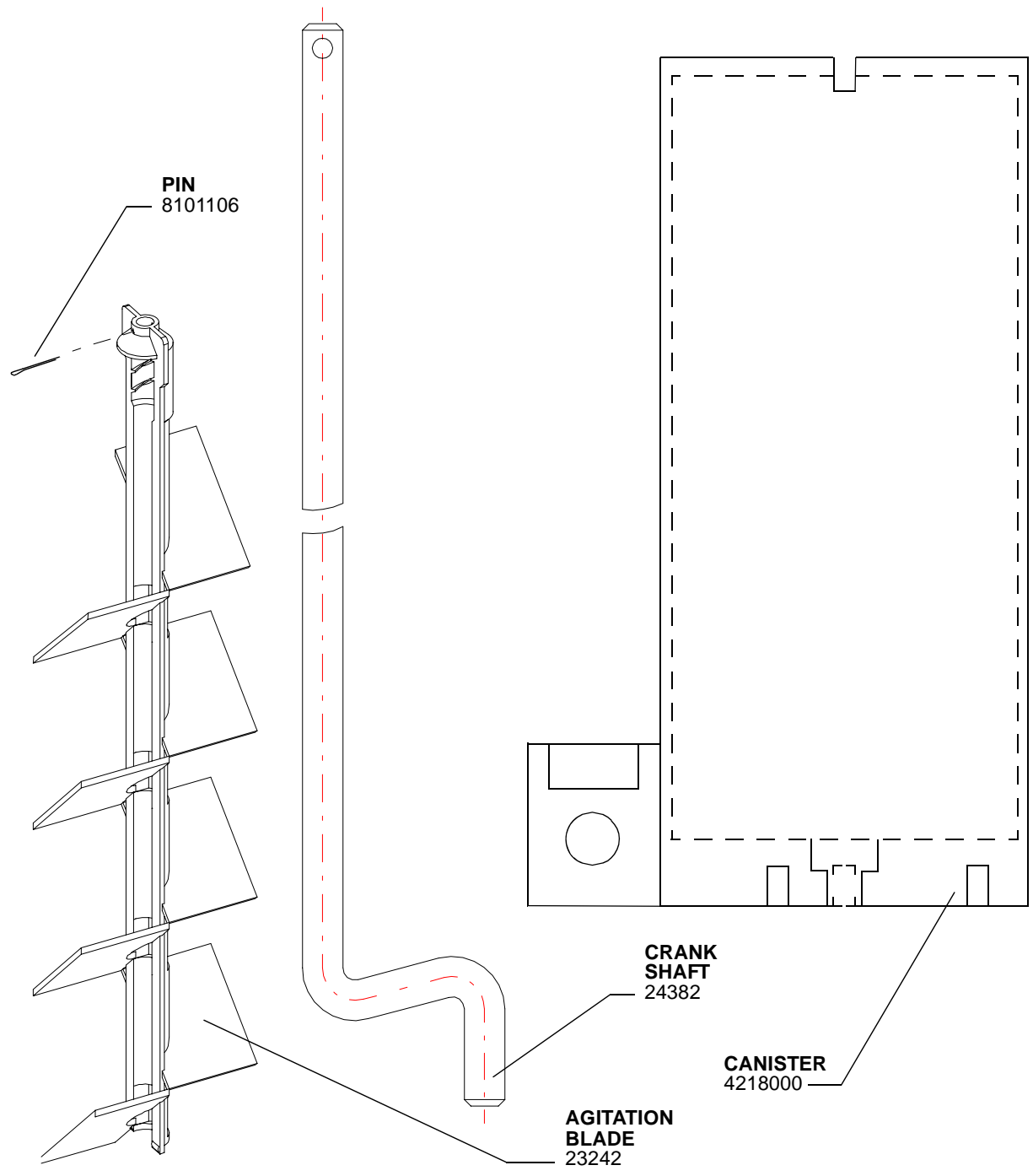

PART NO	DESCRIPTION	NO REQ
23242	AGITATION BLADE	1 PER CANISTER
24382	CRANK SHAFT	1 PER CANISTER
24380	TUBE (NOT SHOWN)	1 PER CANISTER
4218000	CANISTER (80 OZ.)	1 PER CANISTER
4220209	PUMP TUBE AND PISTON (NOT SHOWN)	1 PER CANISTER
4228206	PUMP CAP INDICATOR (NOT SHOWN)	1 PER CANISTER
4220220	PUMP TUBE AND PISTON (NOT SHOWN) <i>(METRIC UNITS ONLY)</i>	1 PER CANISTER
4231000	VITON VALVE ASSY (NOT SHOWN) <i>(VITON OR THIOKOL. NEEDED ONLY, NOT BOTH.)</i>	1 PER CANISTER
4231070	THIOKOL VALVE ASSY (NOT SHOWN) <i>(VITON OR THIOKOL. NEEDED ONLY, NOT BOTH.)</i>	1 PER CANISTER
8101106	PIN	1 PER CANISTER
8100311	TUBE BUSHING (NOT SHOWN)	1 PER CANISTER

PARTS:

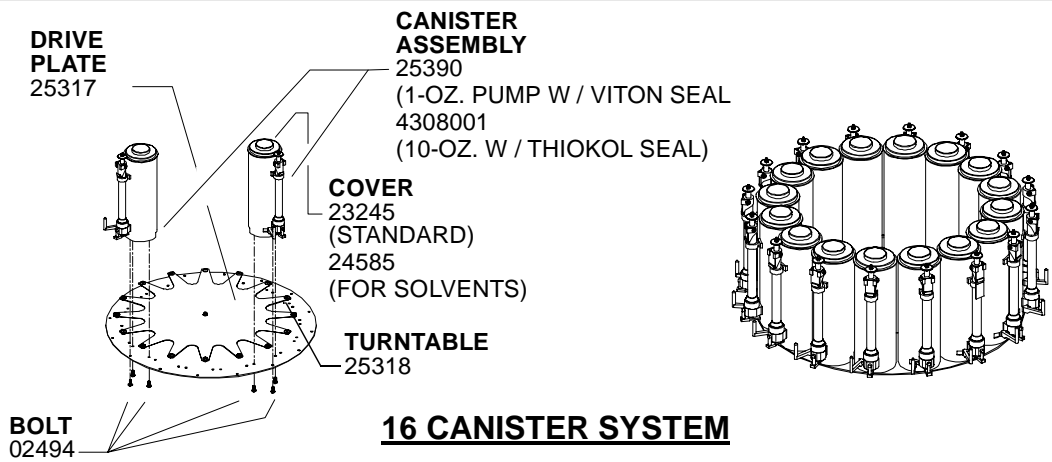
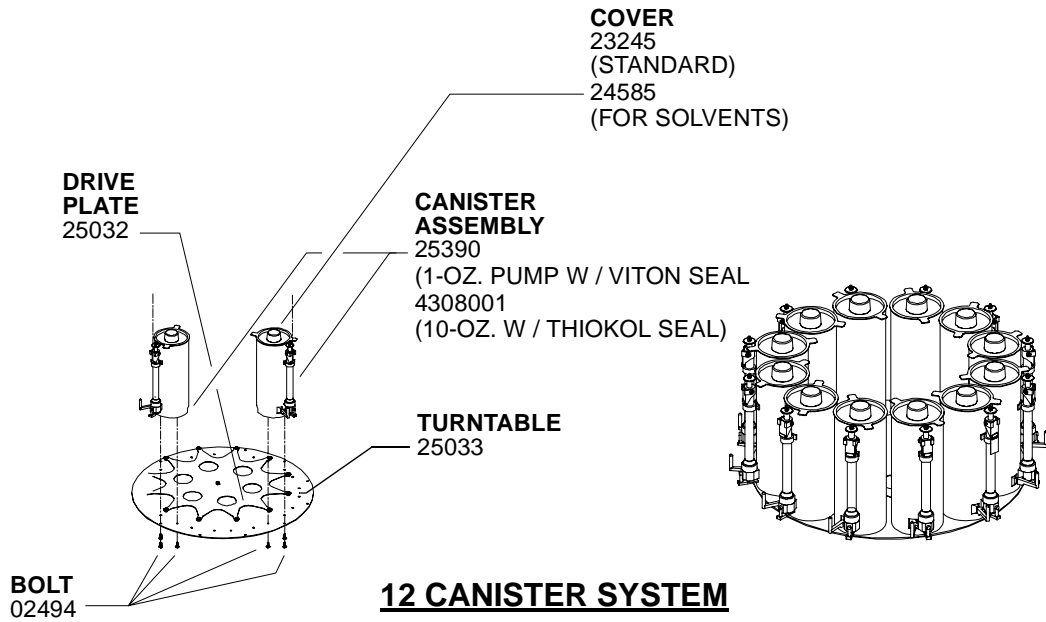

PART NO	DESCRIPTION	NO REQ
02494	MOUNTING BOLT, 14 X 20 X 1/2"	2 PER CANISTER
23245	CANISTER COVER (STANDARD)	1 PER CANISTER
24585	CANISTER COVER (FOR SOLVENTS)	1 PER CANISTER
25032	DRIVE PLATE (12 CANISTER UNITS)	1
25033	TURNTABLE (12 CANISTER UNITS)	1
25316	TURNTABLE (16 CANISTER UNITS)	1
25317	DRIVE PLATE (16 CANISTER UNITS)	1
25390	CANISTER ASSEMBLY (INCLUDES PUMP & VITON VALVE) (1-OZ. PUMP ONLY)	1 PER STATION
4000108	CANISTER ASSEMBLY (INCLUDES PUMP & THIOKOL VALVE) (1-OZ. PUMP ONLY)	1 PER STATION
4308002	CANISTER ASSY (INCLUDING PUMP & VITON VALVE) (METRIC UNITS ONLY)	1 PER STATION

Part No. 4700230

Rev. E

06/07/01

Fluid Management

**1023 Wheeling Road
Wheeling, Illinois 60090-5773**

Telephone: (847) 537-0880

1-800-462-2466

Fax (847) 537-5530

www.fluidman.com

Part No. 4700230

Rev. E

06/07/01